



40' x 60' x 18'

Trussed Commercial Building

Protect Your Investments from Inclement Weather & Sun Damage



MDM Products 40x60 Buildings are designed for heavy commercial, agricultural and industrial use. From the heavy steel galvanized frame to unique dual cover tensioning system, the building is heavy duty from front to back. Typical uses include large workshop areas, animal protection, long term jobsite storage, and multiple truck or car storage. Completely packaged and ready for quick assembly, the frame is the heaviest available in double tubed trussed construction. All frame components are made from heavy galvanized materials. Main Cover, Door, and All Fabrics are made from Long-Life UV Resistant, Fire Retardant Polyethylene with woven backing.

All fabric components feature heat-welded seam construction. Unit features a unique dual cover tensioning system that allows quick adjustment both front-to-back and side-to-side. The easy-up Doors can be winched up from outside the building with little to no effort. Wind release flaps on both sides allow for wind absorption. Long lasting cover design provides for run-off of rain, or melting snow, to avoid water getting in through the perimeter of the cover. Each unit comes equipped with both a set of 22 Earth Anchors and a set of Auger style anchors to secure the unit at all strategic points.



Exclusive Features

- Heavy-Duty Galvanized Finish - All Steel Frame
- Roll Up Mechanical Doors On Both Ends
- Wind Brace Support on Each Corner
- Double Cover Tensioning System
- Complete Anchoring System Included
- 10oz., CPAI-84 Fabric Cover and Doors



Nominal Size	40' Wide x 60' Long x 18' High
Arches	Seven (7) on 68" spacing 2-3/8" diameter frame members
Standard End Door Size	12' Wide x 15' High at edge mechanical roll up design
Colors	Exterior- white Interior - white

Main Cover	fabric backed poly. 10oz weight
Fire Retardant Standard	Main cover and doors meet CPAI-84 Section 5
Anchors	Twenty Two (22) 36" Anchors with U-bolts & drive rod
Shipping Weight	5000 lbs. in three (3) crates shipped via motor freight



MDMshelters.com
RhinoShelters.com



Easy Roll-Up Mechanical Door On Each End



All frame members are long life galvanized steel



Structural wind brace on each corner



Labeled Parts



Side Tensioning Cover Ratchet



Pre-Drilled, Bolt together frame



Heavy-Duty Base Plates

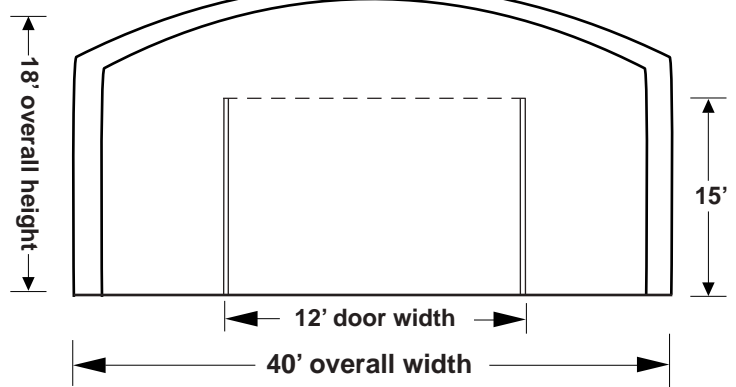
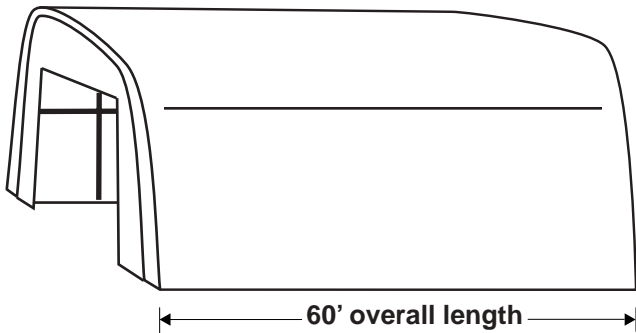

More Fine Products from **Rhino Shelter™**



One Car Garages



SUV/Boat Garages



Large Buildings



Two Car Garages

Car & Cycle Pockets



Party Tents
14' - 32' long



www.RhinoShelters.com

Spec 1Truss
06/08